

auto electrical parts

Technical Information Sheet

Part No. 0-455-63

Lead-free resin cored solder.

13 SWG, 97% tin 3% copper, 0.5kg.



Technical Drawing (not to scale)

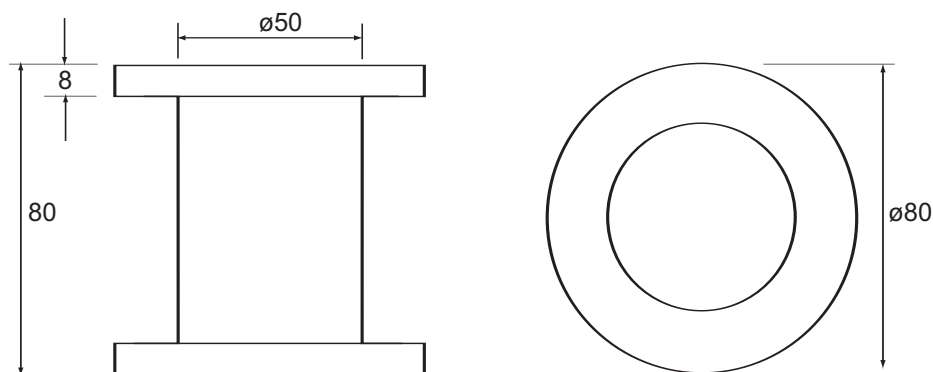

Unwound bobbin

Specification

Type	Lead free cored solder wire
Wire size	2.5mm diameter
Alloy	Sn97 Ag3 (tin, copper)
Flux	RS7MI, activated rosin flux
Liquidus temperature	230 to 250°C
Weight	0.54Kg
Dimensions	ø80 x 80mm
Conformances	Alloy ISO 9543 Manufactured to ISO 12224-1

The information contained in this document is correct to the best of our knowledge at the time of printing. However, specifications may change at any time without notice.